

BALUSTRADE INSTALLATION - OPTION 1

TYPICAL BALUSTER AND RAIL ASSEMBLY

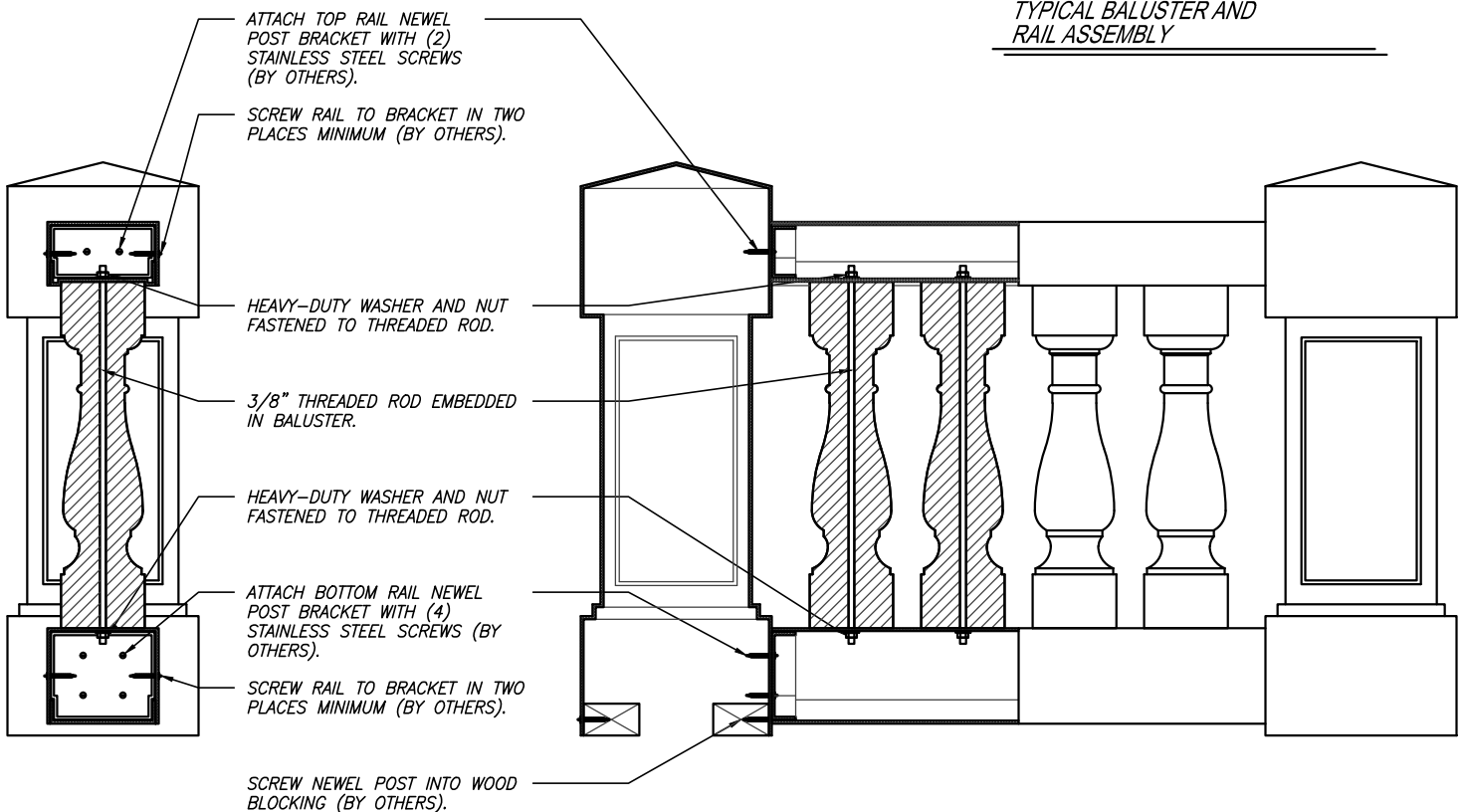

BALUSTRADE INSTALLATION - OPTION 2

BALUSTRADES

SHEET NO.

SD-01

UPDATED: JAN 2010

INSTALLATION



ARCHITECTURAL FIBERGLASS, INC.

8300 BESSEMER AVE., CLEVELAND, OHIO 44127-1839
 (216) 641-8300 - FAX:(216) 641-8150
 www.fiberglass-afi.com

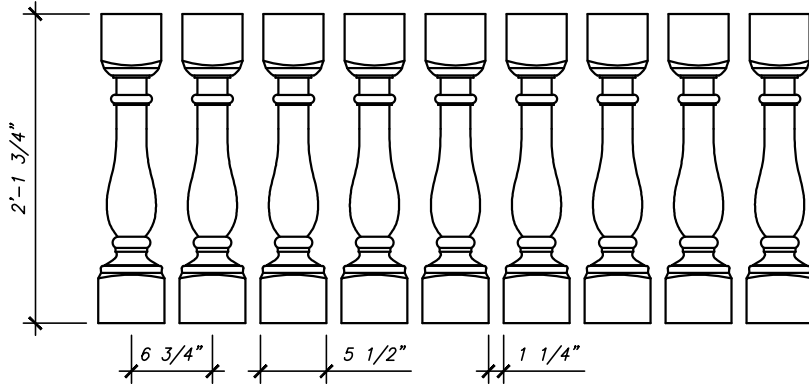

OPTION 1 - 4" SPHERE CODE SPACING

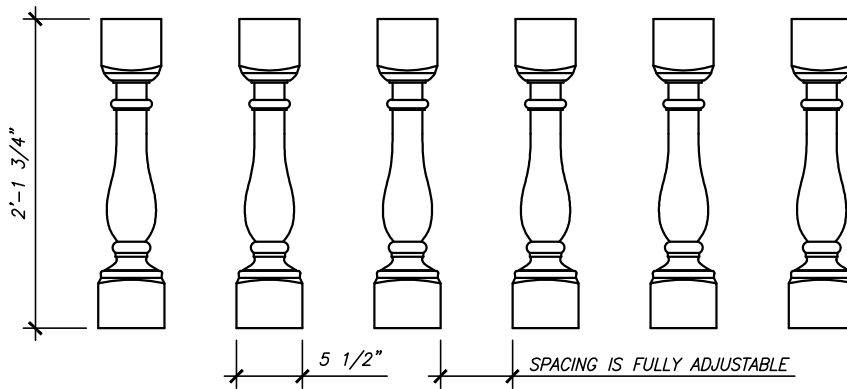

OPTION 2 - SPACING NOT TO CODE

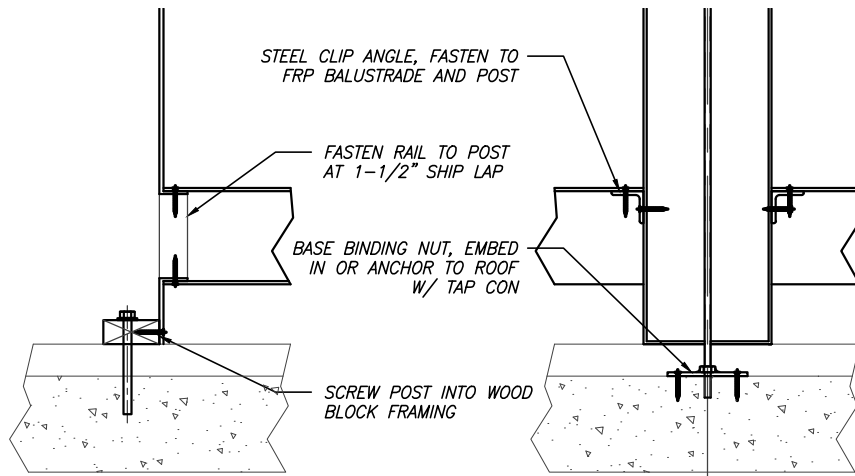

NEWEL POST ATTACHMENT DETAILS

BALUSTRADES

SHEET NO.

SD-02

UPDATED: JAN 2010

INSTALLATION



ARCHITECTURAL FIBERGLASS, INC.

8300 BESSEMER AVE., CLEVELAND, OHIO 44127-1839
 (216) 641-8300 - FAX:(216) 641-8150
 www.fiberglass-afi.com